



New Community Dr.

Kingwood, TX 77345

June 24, 2010

This Limited, Visual Inspection Report is prepared exclusively for

Mr. Custom home upgrade

The front door/garage faces north while the back of master is on the south side. The garage is on the west side of the house and the front bedrooms on the east side for reference to this report.

Real Estate Inspection Service Agreement

The reason for this service agreement is to help you, our client(s), understand what an inspection is and what it can and cannot do for you.

INTENT OF INSPECTION:

The expressed intent and purpose of this report is to inform our client(s) of visual observations and opinions made on the day of the inspection by your inspector. The opinions given are as to whether or not the mechanical, electrical, plumbing and structural components of this property are performing their intended function or are in need of repair. It is not the intent, nor within scope, of this inspection and report to determine if the property is warrantable, insurable, habitable, or to determine the economic life span. The client is advised to solicit information, advice, and cost estimates from licensed professionals in the appropriate trades for all areas of concern prior to the closing process.

SCOPE, METHOD OF INSPECTION AND LIMITATIONS:

The content of this report is based solely upon visual observations and the perceived performance of the different components and not engineering fact. The inspector's opinion is based on his or her personal knowledge, experience, and training, and not upon any code requirements or performance standards. The inspection will be conducted under the standards set forth by the Texas Real Estate Commission. The inspector is not a code compliance officer. Any federal, state or local codes, and / or other legal requirements are not within the scope or intent of this report. The inspector may reference common building code violation for information purposes.

The inspection methodology is limited to openly visible areas of the property. Observations are made on both the inside and outside of the structure. Observations were limited to only those areas open to view without disassembling any component or moving any items which are obstructing the view. The inspector may use basic tools or instruments to aid in the inspection process. Note: stored items, furnishings, recent updating and or repairs may mask typical signs of distress. Because the inspection procedure is visual only and was not intended to be diagnostic and or technically exhaustive some inherent risk remains that undiscovered problems exist and or future problems will develop. There is no guarantee or warranty stated or implied that **all** defects or problems have been found or that Yearly Inspection & Services, LLC will pay for the repair of, or be liable for, any defect not discovered. The report is prepared for the exclusive use for client(s) and Yearly Inspection & Services, LLC and is not transferable to anyone else in any form. Yearly Inspection & Services, LLC assumes no responsibility for its use and / or misinterpretations by third parties.

Recent concerns have included the adverse effects on indoor air quality and the potential of inherent health risks. The client(s) should understand that high moisture conditions for whatever reason may cause various forms of mildew, and / or mold, to flourish. If the client has concerns with such environmental issues, we recommend they contact a qualified professional for further evaluations of this property. Note: houses built prior to 1978 may contain lead based paint. This company does not inspect for lead, mold or any other environmental health hazards. The inspector is not qualified or certified for such evaluations.

Yearly Inspection & Services, LLC will conduct re-inspection services for a reasonable fee. However we do not certify workmanship or warrant another company's repair work. Receipts and/or warranty for work performed should be obtained from the company or companies who have provided repairs.

DISPUTE RESOLUTION

In the event a dispute arises regarding an inspection that has been performed client(s) agrees to notify Yearly Inspection & Services, LLC within seven (7) days of the time of discovery to give Yearly Inspection & Services, LLC a reasonable opportunity to reinspect the property and resolved the dispute amicably. Any unresolved disputes relating to this agreement shall be submitted for mediation and then neither party shall have a right to bring suit in court. This provision shall be specifically enforceable and damages for breach of this provision shall include but not limited to court costs and attorney's fees. The client(s) agrees that Yearly Inspection & Services, LLC liability, if any, shall be limited to the amount of the inspection fee paid.

INDEMNITY

The client agrees to indemnify, defend and hold harmless; the inspector all officers and subcontractors to Yearly Inspection & Services, LLC, attorneys or agents, in any action brought against any such party with respect to any and all claims, demands, causes of action, debts or liabilities, including reasonable attorneys fees rising out of or relating to this agreement or property inspection whether or not resulting from the negligence of any party so indemnified, unless the cause is proved to be gross negligent action or intentional misconduct of the inspector.

ACCEPTANCE OF THE REPORT

In the absence of a client signature on this service agreement prior to or at the time of the inspection, this contract shall be included and become part of the report. Acceptance of the report, and or payment for the inspection is an acknowledgment, acceptance, and agreement by the client(s) to the terms and conditions of this service agreement. Including the limitations listed in the report, and an acknowledgment that the inspection includes only those items listed as inspected in the inspection report.

Client Name:

Property address:

Today's Inspection Fee: \$500.00
Make Check payable to: Yeary Inspection & Services, LLC
CK # PAID AT INSPECTION

Client Signature(s):

_____ Date: ____/____/ 2010
_____ Date: ____/____/ 2010

By signing I confirm that I have read, understand, and agree to the above pre-inspection service agreement and that I agree to be bound by these terms and conditions.

We will be sending the report out over the internet via E-mail, most of our clients want a copy sent to their realtor. We will gladly provide a copy to your realtor as long as you provide us with an E-mail address for them.

Your E-mail addresses:

Your Realtors E-mail address:

Please check if you do not want us to send the report to your realtor.

We will gladly send a copy to the seller, seller's realtor, or any other party that you direct us to:

E-mail addresses of other report recipients:

Inspector: Kyle Yeary TREC Professional Inspector License #9819 Date: 6/24/2010

TEXAS REAL ESTATE CONSUMER NOTICE CONCERNING HAZARDS OR DEFICIENCIES

Each year, Texans sustain property damage and are injured by accidents in the home. While some accidents may not be avoidable, many other accidents, injuries, and deaths may be avoided through the identification and repair of certain hazardous conditions.

Examples of such hazards include:

- improperly installed or missing ground fault circuit protection (GFCI) devices for electrical receptacles in garages, bathrooms, kitchens, and exterior areas;
- improperly installed or missing arc fault protection (AFCI) devices for electrical receptacles in family rooms, dining rooms, living rooms, parlors, libraries, dens, bedrooms, sunrooms, recreations rooms, closets, hallways, or similar rooms or areas;
- ordinary glass in locations where modern construction techniques call for safety glass;
- the lack of fire safety features such as smoke alarms, fire-rated doors in certain locations, and functional emergency escape and rescue openings in bedrooms;
- excessive spacing between balusters on stairways and porches;
- improperly installed appliances;
- improperly installed or defective safety devices; and
- lack of electrical bonding and grounding.

To ensure that consumers are informed of hazards such as these, the Texas Real Estate Commission (TREC) has adopted Standards of Practice requiring licensed inspectors to report these conditions as "Deficient" when performing an inspection for a buyer or seller, if they can be reasonably determined.

These conditions may not have violated building codes or common practices at the time of the construction of the home, or they may have been "grandfathered" because they were present prior to the adoption of codes prohibiting such conditions. While the TREC Standards of Practice do not require inspectors to perform a code compliance inspection, TREC considers the potential for injury or property loss from the hazards addressed in the Standards of Practice to be significant enough to warrant this notice.

Contract forms developed by TREC for use by its real estate licensees also inform the buyer of the right to have the home inspected and can provide an option clause permitting the buyer to terminate the contract within a specified time. Neither the Standards of Practice nor the TREC contract forms requires a seller to remedy conditions revealed by an inspection. The decision to correct a hazard or any deficiency identified in an inspection report is left to the parties to the contract for the sale or purchase of the home.

This form has been approved by the Texas Real Estate Commission for voluntary use by its licensees. Copies of TREC rules governing real estate brokers, salesperson and real estate inspectors are available at nominal cost from TREC. Texas Real Estate Commission, P.O. Box 12188, Austin, TX 78711-2188, 1-800-250-8732 or (512) 459-6544 (<http://www.trec.state.tx.us>)

TREC Form No. OP-1

This form is available on the TREC website at www.trec.state.tx.us

Yeary Inspection & Services, LLC

14419 Hartshill Dr., Houston, TX 77044

Phone: (281)454-4663 Fax: (281)454-4663 Email: yearyinspection@sbcglobal.net

PROPERTY INSPECTION REPORT

Report #: KY20100701-01

Prepared For: Custom builder 2010 New Final
(Name of Client)

Concerning: TX -
(Address of Inspected Property)

By: Kyle Yeary, #9819 7/1/2010
(Name and License Number of Inspector) (Date)

This property inspection report may include an inspection agreement (contract), addenda, and other information related to property conditions. If any item or comment is unclear, you should ask the inspector to clarify the findings. It is important that you carefully read ALL of this information.

This inspection is subject to the rules ("Rules") of the Texas Real Estate Commission ("TREC"), which can be found at www.trec.state.tx.us.

The TREC Standards of Practice (Sections 535.227-535.233 of the Rules) are the minimum standards for inspections by TREC-licensed inspectors. An inspection addresses only those components and conditions that are present, visible, and accessible at the time of the inspection. While there may be other parts, components or systems present, only those items specifically noted as being inspected were inspected. The inspector is not required to move furnishings or stored items. The inspection report may address issues that are code-based or may refer to a particular code; however, this is NOT a code compliance inspection and does NOT verify compliance with manufacturer's installation instructions. The inspection does NOT imply insurability or warrantability of the structure or its components. Although some safety issues may be addressed in this report, this inspection is NOT a safety/code inspection, and the inspector is NOT required to identify all potential hazards.

In this report, the inspector will note which systems and components were Inspected (I), Not Inspected (NI), Not Present (NP), and/or Deficient (D). General deficiencies include inoperability, material distress, water penetration, damage, deterioration, missing parts, and unsuitable installation. Comments may be provided by the inspector whether or not an item is deemed deficient. The inspector is not required to prioritize or emphasize the importance of one deficiency over another.

Some items reported as Deficient may be considered life-safety upgrades to the property. For more information, refer to Texas Real Estate Consumer Notice Concerning Recognized Hazards, form OP-I.

This property inspection is not an exhaustive inspection of the structure, systems, or components. The inspection may not reveal all deficiencies. A real estate inspection helps to reduce some of the risk involved in purchasing a home, but it cannot eliminate these risks, nor can the inspection anticipate future events or changes in performance due to changes in use or occupancy. It is recommended that you obtain as much information as is available about this property, including any seller's disclosures, previous inspection reports, engineering reports, building/remodeling permits, and reports performed for or by relocation companies, municipal inspection departments, lenders, insurers, and appraisers. You should also attempt to determine whether repairs, renovation, remodeling, additions, or other such activities have taken place at this property. It is not the inspector's responsibility to confirm that information obtained from these sources is complete or accurate or that this inspection is consistent with the opinions expressed in previous or future reports.

ITEMS IDENTIFIED IN THE REPORT DO NOT OBLIGATE ANY PARTY TO MAKE REPAIRS OR TAKE OTHER ACTIONS, NOR IS THE PURCHASER REQUIRED TO REQUEST THAT THE SELLER

Report Identification: _____

TAKE ANY ACTION. When a deficiency is reported, it is the client's responsibility to obtain further evaluations and/or cost estimates from qualified service professionals. Any such follow-up should take place prior to the expiration of any time limitations such as option periods. Evaluations by qualified tradesmen may lead to the discovery of additional deficiencies which may involve additional repair costs. Failure to address deficiencies or comments noted in this report may lead to further damage of the structure or systems and add to the original repair costs. The inspector is not required to provide follow-up services to verify that proper repairs have been made.

Property conditions change with time and use. For example, mechanical devices can fail at any time, plumbing gaskets and seals may crack if the appliance or plumbing fixture is not used often, roof leaks can occur at any time regardless of the apparent condition of the roof, and the performance of the structure and the systems may change due to changes in use or occupancy, effects of weather, etc. These changes or repairs made to the structure after the inspection may render information contained herein obsolete or invalid. This report is provided for the specific benefit of the client named above and is based on observations at the time of the inspection. If you did not hire the inspector yourself, reliance on this report may provide incomplete or outdated information. Repairs, professional opinions or additional inspection reports may affect the meaning of the information in this report. It is recommended that you hire a licensed inspector to perform an inspection to meet your specific needs and to provide you with current information concerning this property.

ADDITIONAL INFORMATION PROVIDED BY INSPECTOR

Present at Inspection: Buyer Selling Agent Listing Agent Builder
Building Status: Vacant/builder Builder Occupied Tenant Occupied
Weather Conditions: Fair Cloudy Rain

The outside temperature was around 87 F in the shade upon the 12:00 PM start time and around 85 F in the shade at the 8:00 PM departure. A laser thermometer is used so is not an accurate ambient temperature check.

Utilities On: No Water No Electricity No Gas

Special Notes:

INACCESSIBLE OR OBSTRUCTED AREAS

Sub Flooring Areas Attic Space is Limited - Viewed from Accessible

Floors Covered Inspected Plumbing Areas - Only Visible Plumbing

Walls/Ceilings Covered; Freshly Painted inside and/or vines covering wall outside

Siding Over Older Existing Siding Behind/Under Furniture and/or Stored Items

Mold/Mildew investigations are NOT included with this report, it is beyond the scope of this inspection at the present time. Any reference of water intrusion, is recommended that a professional investigation be obtained.

Some homes may be located in high wind areas and some municipalities or Insurance providers may require a Windstorm Certificate. Recommend for client to further investigate if this home requires a certificate and a Texas website is provided to help with this process; tdi.state.tx.us/windstormsearch;

This report does not verify nor is inspected to identify the Country of origin, manufacturing type, plant, durability, insurability of any product, lumber and including and not limited to dry wall sheet rock.

This report has some pictures present as examples only of some, but not limited to all, areas of attention and in no way can be used as a way to gain estimates.

NOTICE: THIS REPORT IS PAID FOR BY AND PREPARED FOR THE CLIENT NAMED ABOVE.

THIS REPORT IS NOT VALID WITHOUT THE SIGNED SERVICE AGREEMENT AND IS NOT TRANSFERABLE. THIS REPORT IS PROPERTY OF YEARY INSPECTION LLC. WITH ALL RIGHTS RESERVED.

I=Inspected

NI=Not Inspected

NP=Not Present

D=Deficient

I NI NP D

I. STRUCTURAL SYSTEMS

⌋ ⋮ ⋮ ⌋

A. Foundations

Type of Foundation(s): Slab

Comments:

Signs of Structural Movement or Settling

- ⋮ Cracks in wall(s) and/or ceiling;
- ⋮ Floors visibly not level
- ⋮ Cracks in brick, stone, or stucco;
- ⌋ Cracks in exposed concrete floors; few small chips in garage,



- ⋮ Door and/or window frames out of square

⌋ Cracks in sidewalks, driveway, patio or garage which is very common; may seal at front patio along wall, end of driveway to name some.



- ⋮ Cracks in slab on outside edge;
- ⋮ Beam/Rafter condition and/or Pier Condition which if rafters have pulled away from the ridge board or split should be blocked or repaired;
- ⋮ Excessive or improper shims

⌋ Wood form strips or other wood observed next to the slab which are conducive to wood destroying insects, which could be removed and replaced along with all cracks sealed with blown in foam covered with a thick layer of caulking; front patio area against wall.



- ⋮ Post tension live end tips are exposed and should be covered;

⌋ Nails or metal is exposed which could be a hazard and could be removed and covered; noticed side of garage.

I=Inspected

NI=Not Inspected

NP=Not Present

D=Deficient

I	NI	NP	D
---	----	----	---



- Soil is high and should be removed away from the brick so that there is a 6 inch decline at 10 feet away from the foundation which is a cause of foundation settlement;
- Observed typical spalling (crumbling of slab) or honey combing. This can be epoxied or touched up and usually happens around the corner/edges of the slab because the stress will break the slab.
- Low spots around house allowing water to pond against the slab - recommend placing a gutter system with downspouts and splash pads if not present and repair the drainage issues
- Observed trees are very close to the structure in areas which tend to pull water from underneath the slab and may cause heaving or foundation issues:

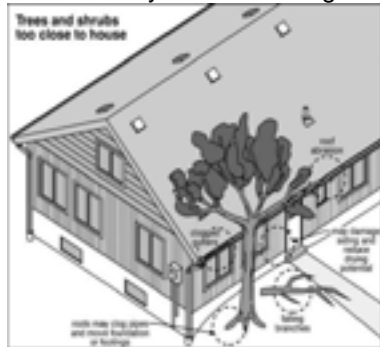

Should always seal any opening between concrete sections with blown in foam covered with a thick layer of caulking;

Performance Opinion:

Note: *Weather conditions, drainage, leakage, and other adverse factors are able to effect structures, and differential movements are likely to occur. The inspectors opinion is based on visual observations of accessible and unobstructed areas of the structure at the time of the inspection. Future performance of the structure cannot be predicted or warranted.*

⌋ The foundation appears to be performing the function intended;

SUGGESTED FOUNDATION MAINTENANCE & CARE - *Proper drainage and moisture maintenance to all types of foundations due to the expansive nature of the area load bearing soils. Drainage must be directed away from all sides of the foundation with grade slopes. In most cases, floor coverings and/or stored articles prevent recognition of signs of settlement - cracking in all but the most severe cases. It is important to note, this was not a structural engineering survey nor was any specialized testing done of any sub-slab plumbing systems during this limited visual inspection, as these are specialized processes requiring excavation. In the event that structural movement is noted, client is advised to consult with a Structural Engineer who can isolate and identify causes, and determine what corrective steps, if any, should be considered to either correct and/or stop structural movement.*

I=Inspected

NI=Not Inspected

NP=Not Present

D=Deficient

I	NI	NP	D
---	----	----	---

⌋ ⋮ ⋮ ⌋

B. Grading and Drainage - Comments:

⌋ Improper drainage from foundation and not a decline at all locations away from slab and/or a 6 inch decline at 10 feet away or less than a 5% slope to swale when barrier prevents 6in/10ft; front mulch needs adjusting.

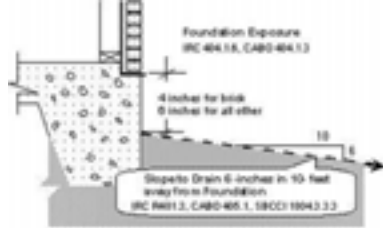

⌋ Erosion or ponding next to foundation/driveway or in yard; may adjust or monitor back corner, under valley runoff,



- ⋮ Gutters draining too close to the structure;
- ⋮ Plumbing/Hose Bibb(s)/Sprinkler System leakage
- ⋮ Trees/heavy foliage too close to the structure
- ⋮ A/C condensation line terminates too close to structure
- ⋮ Planter(s) adjoining the structure;
- ⋮ Inadequate grading clearance (high soil) to exterior wall surface;
- ⋮ French or corrugated drain system is clogged or blocked;

⌋ Downspout is missing the splash blocks at several locations causing water to sit against the house;



- ⋮ Observed the foundation elevation was less than 12 inches + 2% above the street drain.
- ⋮ Could consider adding a gutter system in all locations to divert the water away;

French or corrugated drain system that should be monitored for leaks so that water does not seep into the ground and work under the slab;

Note: A regular watering plan should be imposed in order to keep the moisture level stable around the entire foundation. Determining the correct amount of water to place next to the foundation without undermining the grade beams can be difficult, and varies widely depending on the type of soil the house was built on. Also need to consider the gutter system must be clear of debris and attached properly to divert water from the foundation, which is the overall design. Gutters and water diverting systems are a good way to keep water from ponding against the house and please consider that a 6 inch decline is required 10 feet away from the house to ensure that water will not pond against the

I=Inspected

NI=Not Inspected

NP=Not Present

D=Deficient

I	NI	NP	D
---	----	----	---

house. If any wall is Portland Plaster Cement it must be protected from water run off.

⌋ " " ⌋

C. Roof Covering Materials

Type(s) of Roof Covering: Shingles - Asphalt

Viewed From: walked roof

Comments:

⌋ Some damaged or raised shingles throughout; 1 tear, a few raised on front over garage and ridge, several discolored/scuffed under front dormer and back noticed;

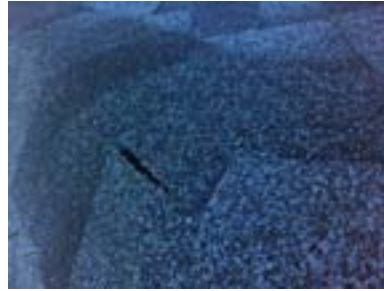
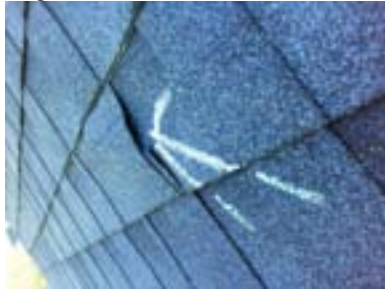

" Observed less than a 4 fastener minimum nailing pattern or staples in use if shingle could be lifted without damaging;

" Roof decking deflection, raised and/or sagging;

" Roofing covering installed over older roof covering

" Inappropriate roof covering for slope of the roof;

⌋ Observed some exposed nails and/or staples showing that should be covered or caulked as part of routine maintenance; a few nailed low,



" Trim, soffit, fascia boards are in need of repair;

I=Inspected

NI=Not Inspected

NP=Not Present

D=Deficient

I	NI	NP	D
----------	-----------	-----------	----------

- .. Roof covering is in contact with siding;
- .. Leaves/debris in the gutters and downspouts;
- .. Tree branches are too close to the roof structure;
- .. Roof ventilation system damaged and in need of repair
- .. Drain,waste vents missing, deteriorated (some have been chewed and/or cracks around boot where water can enter around) or improper installation (less than 6 inches above roof or 10ft horiz or 2ft above openings or 12in to vert surface) or not protected with latex paint observed;
- .. Loose, missing and/or damaged gutters or downspouts;
- .. Underlayment should be over the rake edge flashing at the front and back eaves and be tucked under at the sides so rain water will not get between the flashing and wood and cause water penetration;



- .. Observed the shingles are loose or not-glued down properly to the edge of the drip edge flashing (poor starter course);

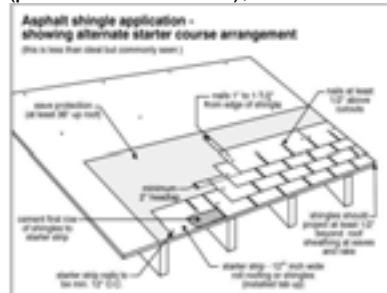

- ⊆ Debris, nails, straw, and/or leaves on the roof that must be kept clean so that it does not damage the roof;
- .. Roof penetration(s) or flashing not properly secure, flashed/sealed;
- .. Brick chimney not properly flashed and counter-flashed;
- .. Skylight covers not secured and/or flashed properly
- .. Chimney cricket/saddle is missing if 30+ inches wide or not the proper height;

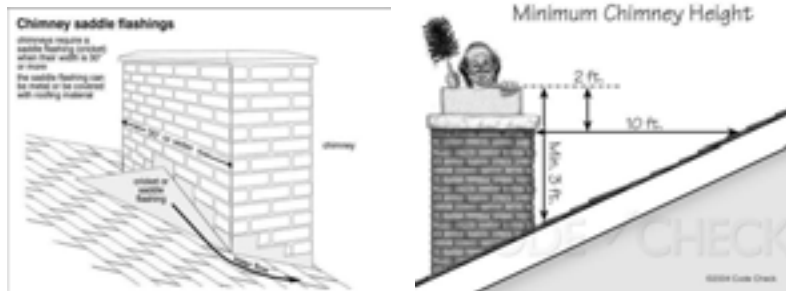

- .. Missing rain skirts on metal fireplace or furnace flues
- .. Missing/damaged rain caps on furnace/water heater flues
- ⊆ Storm collars are not caulked completely on furnace/water heater flues and/or could view daylight from attic access;furnace,

I=Inspected

NI=Not Inspected

NP=Not Present

D=Deficient

I NI NP D

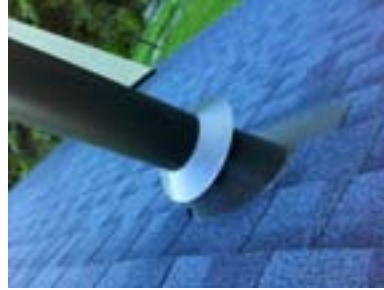

⌋ Flashing in need of repair; may paint valley flashing,



- ⋮ Missing/damaged rain caps on metal fireplace flues
- ⋮ Step flashing is not in use (about 10 inch sheets) where a roof intersects at exterior wall which is the type approved per most manufactures (GAF) and J or L-flashing (long continuous sheet, which if water enters could run continuous) is in use;

⋮ The roof covering is in need of repairs or replacement, a Certified Roofing Company should be consulted

Caulking is recommended around all flashing, all roof jacks, air vents, and vent pipes as part of routine maintenance

Note: This is not a Windstorm Inspection. If Windstorm Certification is required in your area you should obtain any available certification that might be required for windstorm insurance, or contact State of Texas Department of Insurance.

Attempt to lift shingles to analyze the nailing pattern when loose or determine that is safe to do so without damaging the overall integrity of the covering, however cannot always view and at minimum confirmed nail usage vs. staples from the attic access.

⌋ ⋮ ⋮ ⌋

D. Roof Structure and Attic

Viewed From: Entered attic access

Approximate Average Depth of Insulation: 8 to 12 inches

Approximate Average Thickness of Vertical Insulation: sheathing board

Comments:

Attic Issues:

- ⋮ Insufficient attic ventilation or fans/vents not working properly; The total net free ventilating area shall not be less than 1 to 150 of the area of the space ventilated except that the total area is permitted to be reduced to 1 to 300 provided at least 50 percent and not more than 80 percent of the required ventilating.

I=Inspected

NI=Not Inspected

NP=Not Present

D=Deficient

I NI NP D

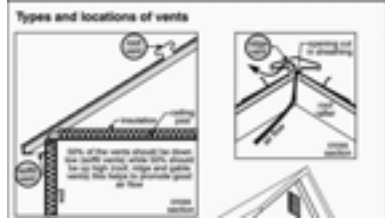

- .. This house does not have a radiant barrier installed and most new homes have for energy efficiency;
- ⌋ Dormers;unpainted windows;preference if homeowner wants painted;



- .. Damaged and/or missing roof sheathing
- .. Openings observed around corners of attic that should be blocked;
- ⌋ Roof support; observed 1 or more rafters that are not fully flush against the ridge board (some poor cuts) or *do not meet or align on both sides (off tension) which could be blocked*,another rafter next too sistered past the purlins or other methods or just monitored;some specifics are a poor cut over living area furnace,garage and marked a few,however no immediate cause for concern,



- ⌋ Roof support from ridge boards (min.1x & full depth of cut rafter),rafters,bracing (2x4 max. 45% from vert), purlins (no smaller than rafter), collar ties (can be 1x4,upper 1/3 of roof section) may not **adequate**; a few rafters on kitchen side in center are nailed off center down past ridge board and a brace is loose in front of hall access and marked;

I=Inspected

NI=Not Inspected

NP=Not Present

D=Deficient

I	NI	NP	D
---	----	----	---



- ⋄ Bath/Kitchen vents terminating in attic or not properly sealed at roof decking;
- ⋄ Evidence of moisture penetration
- Open raceway from the garage to the house which should be blocked at the garage with a fire rated material. This creates an open chimney if a fire occurred and should be fire blocked;
- ⌋ Open chase should be fire blocked every 10 feet horizontally or vertically including around duct penetrations, between floors, and other openings and currently if a fire occurred could serve as a chimney;side front wall,



- Roof sag due to the decking should have more support. May try to add the h clips or fasteners
- Observed exposed and hot wires throughout the attic;
- ⋄ Observed exposed gas or drain/water pipes that are loose or out in the walkway and should be blocked or strapped throughout;
- ⋄ Observed debris,lumber,trash throughout the attic that should be removed;old parts,lights etc,
- ⋄ Observed an inadequate walkway or platform to mechanical equipment in the attic. **Current code requires 30 inches of head clearance, a 24 inch solid walkway with no obstructions and a 30 inch deep solid platform in front of the equipment and must be flat flush secure surface;**

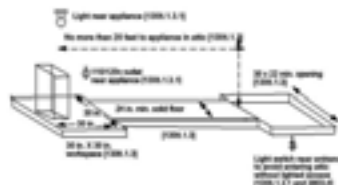

- ⌋ Current regulation requires all wires within 6 feet of the attic opening to be protected and observed unprotected electrical wires near the opening. This could lead to wire damage and possible electrical shock or potential fire hazard.;master access.

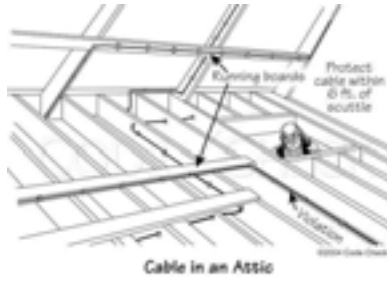

- Observed an exhaust vent that is in contact with a combustible material
- Observed an inadequate access opening of less than 22x30 inches when equipment is in attic

I=Inspected

NI=Not Inspected

NP=Not Present

D=Deficient

I	NI	NP	D
---	----	----	---

and/or not a fire rated door.

• Add or adjust soffit vent blocks so that the soffit air flow is not restricted which must have a 1 inch min clearance near vents, (806.3)

⌋ The recessed lights should be Insulated ceiling lights since insulation or combustibile material is touching the canister or closer than 3 inches. Even when these lights are air-tight or IC lights it is a good idea to pull all insulation away from the canisters because they can shut off due to getting too hot;over master tub going off and on,



Attic Door:

⌋ Lack of weather-stripping on the outside edge of hall access;



- Lack of insulation around the edge of the attic trim;
- Lack of or did not appear to be a fire rated door;
- Gap in door when closed that should be adjusted so air does not escape
- Stairs should be trimmed so that it rests flush against the floor. The strain could eventually break the steps;

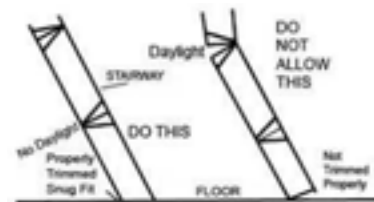

The attic door frame require 16D (penny) nails or 1/4 x 3" or equivalent screws through the hinges and around the frame and should have 16 fasteners attached unless the door manufacture lists or requires a different pattern. This door has about 17 or more larger fasteners now;

⌋ Lack of fasteners through all brackets or brackets missing on edge for proper support; missing on 2, several in master and garage access,

I=Inspected

NI=Not Inspected

NP=Not Present

D=Deficient

I	NI	NP	D
---	----	----	---



;

Insulation:

Type: " Batts] Blown-in-measured about 13 inches by access opening.

" Noticed an area that should have insulation added or extra layers throughout

Note: The attic was entered and walked around the mechanical equipment if accessible and toward the bath/exhaust fans, however portions of the roof structure and attic could not be inspected due to accessibility. It is recommended to have 30 R (12 to 16 inches) and may be 50 R (19 or more) soon for the best efficiency. Above are some specific items that may need attention.

] " "]

E. Walls (Interior and Exterior) - Comments:

Interior Walls:

" Signs of Structural Settling;

" Signs of water stains or water penetration - measured with a moisture meter set on gypsum for sheet rock and registered _% moisture content which is dry and may want to repair past damage at:

" Signs of water stains or water penetration - measured with a moisture meter set on wood for trim work and registered _% moisture content which is dry and may want to repair the past damage at:

] Freshly Painted;

" Holes in walls;may be behind doors because lack of door stops.

" Observed walls or structure is out of square or bowed in areas:

" Nail pops observed that could be repaired

] Gaps or cracks underneath sinks around pipes,outlets, etc.;may seal under kit sink,

" Past water damage underneath sinks;

] Cabinets,counter,mirror or drawer issues:some chips marked,nail through peninsula,no hardware or bumpers inside,clean counter and scratches,seam in kitchen counter,cabinet doors by dishwasher not aligned properly,



I=Inspected

NI=Not Inspected

NP=Not Present

D=Deficient

I	NI	NP	D
---	----	----	---



∴ Caulking/sealant is separated or missing in some areas;
∴ Trim boards, shelves/racks or hardware is damaged/loose at several areas
⌋ Observed several paint discolorations and scuff marks throughout the house;some marked in kitchen,pantry,bathroom,around master tub,



⌋ Observed several paint chips or sheet rock cracks throughout;several in garage,



Note: Due to fresh paint in several rooms it is hard to notice what is behind the walls in each situation.

Note: All trim work, window sills, bathrooms, commodes, cabinets, floors, water pipes and other penetrations around the interior should be examined and improved as needed to provide a solid seal (caulk) against water penetration.

Exterior Walls

Type(s): ⌋ Brick ⌋ Cement Board ∴ Wood ∴ Stone ⌋ Portland Plaster Cement
∴ May be asbestos siding;

⌋ Fascia/trim boards are damaged at several areas;some damage in front patio,may address in front,seal or add trim at bottom of garage,

I=Inspected

NI=Not Inspected

NP=Not Present

D=Deficient

I	NI	NP	D
---	----	----	---



⌋ Mortar is separated or missing in some areas;between some bricks at corners,around windows,front or back porches,front fence.



⌋ Caulking/sealant is separated or missing in some areas and should block/seal any and all openings between the wall and trim work,b/t brick and stucco,



∴ Some cracks at the brick, stone, or stucco siding
∴ Wood siding is water damaged in several areas;
⌋ Siding shingles are cracked, loose or missing;plaster scrape on back patio,buckled on top of chimney,back of outside chimney to name some.

I=Inspected

NI=Not Inspected

NP=Not Present

D=Deficient

I NI NP D

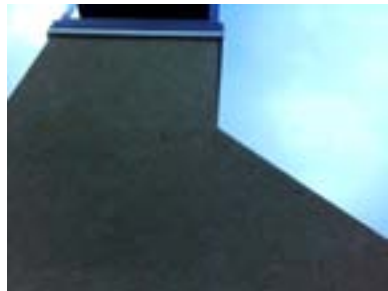

- .. Stucco not a 3 coat system, weep screed not a min of 4 in to earth or 2 in above paving,
- .. Observed walls or structure is out of square, bowed or warped in areas:
- ⌋ Some siding fasteners are backing out, overdriven nails or metal exposed around; nail on side of front bedroom,



- .. Some above door and window lintels are rusted and should be sanded and painted.
- .. Weep holes not open and/or improper spacing of over 33" on center;
- .. Flashing missing for door and window openings;
- .. One or more areas were obstructed by foliage and/or other items; all around should be cut back,

Note: All openings and penetrations around the exterior should be examined and improved as needed to provide a solid seal (caulk) against water penetration. This includes all trim, plumbing water and gas pipes, electrical boxes and air conditioning flashings that break the wall.

⌋ .. ⌋

F. Ceilings and Floors - Comments:

Note: All trim work, window sills, bathrooms, commodes, cabinets and other penetrations around the interior should be examined and improved as needed to provide a solid seal (caulk) against water penetration.

Ceilings:

Note: Due to fresh paint in several rooms it is hard to notice what is behind the ceilings and floors in each situation.

- ⌋ Ceiling cracks or imperfections in some areas (very common in vaulted ceilings) at; master bathroom,
- .. Water stains on ceiling - measured with a moisture meter set on gypsum for sheet rock and registered .1% moisture content which is dry and past damage could be repaired;
- ⌋ Paint discolorations; kitchen, scratch in formal, master bath shower, center of master, paint around

I=Inspected

NI=Not Inspected

NP=Not Present

D=Deficient

I	NI	NP	D
---	----	----	---

kitchen fixtures to name some,



- ⌋ Freshly painted;
- ∴ Nail pops in ceiling which could be addressed;
- ∴ Caulk or trim pull away from the ceiling which should be addressed
- ∴ Substance on ceiling
- ∴ Observed ceilings are out of square or bowed in areas:
- ∴ Observed ceiling height in a habitable space is under 7 ft except 6ft 8 in over bath over fixtures and front clearance,(305.1 IRC);

Floors:

Note: Due to all the carpet and floor coverings all imperfections, cracks and other issues may not be discovered after one visit.

- ⌋ Floor cracks, scratches, or grout/seal openings in some areas;grout opening in center of living room,back kitchen door and a few scratches,



- ∴ Paint stains on floor;
- ∴ Linoleum or floor covering is torn and/or some carpet trim is exposed or needed,
- ⌋ Carpet and floor covering is stained;stain in middle room,



- ∴ Freshly painted or stained floor

I=Inspected

NI=Not Inspected

NP=Not Present

D=Deficient

I	NI	NP	D
---	----	----	---

∩ Floors were uneven or creaked when walked across or warped/bowed in areas:

⊔ Observed tiles that sounded hollow when tapped with a hard object which is a result of lack of adhesive spread evenly underneath tile, loose tile, air pockets or water has penetrated underneath the tile. Discovered 0 or more in the front entry, 0 or more in the kitchen, 0 or more in laundry, 0 or more in bathroom and 1 or more in master hall wing.



⊔ ∩ ∩ ⊔

G. Doors (Interior and Exterior) - Comments:

Interior Doors

⊔ Damaged doors at: paint discolorations, laundry, bedroom doors, most other sliding doors,



⊔ Doors do not latch properly and/or striker plates need adjusting at: middle bedroom closet,

- ∩ Doors are loose at the hinges at:
- ∩ Doors rub, stick, swing independently or hit the frames at:
- ∩ Closet doors slide poorly, off of their rails or missing at;
- ∩ Doorknobs are in need or repair or loose throughout at:

Exterior Doors

- ∩ Sliding glass door slides poorly or improperly installed at:
- ∩ Sliding glass door does not latch/lock properly at:
- Sliding or other screen door is missing/damaged at:
- ∩ Damaged doors at:
- ∩ Damaged threshold or over the max. of 1 1/2 height:
- ∩ Safety glass logo not present at:
- ⊔ Doors sealed poorly or add foam weather stripping: tear on garage door.

- ∩ Doors do not latch properly at:
- ∩ Doors are loose at the hinges at:
- Doors rub, stick, swing independently or hit the frames at:
- ∩ Door locks or doorknobs are in need of repair or loose at;

[Most prudent homeowners replace all exterior locks prior to move in. Most new construction keys are re programmed to change locks for buyers.](#)

- ∩ All Inside key locked deadbolt locks must be thumb latched or openable from the side without the use of a key or special knowledge by IRC standards, (311.4.4) for emergency egress reasons.
- ∩ Deadbolt locks, do not extend to properly lock the doors at:
- ∩ Exit door not side hinged, not less than 3 feet in width and 6 feet 8 inches in height or a direct access to exterior at;
- ∩ Observed that the automatic self closing device/hinge required by current IBC (International Building Code) on the door between the house and the garage needs adjustment to operate properly or is not present. [This is recommended to help prevent fumes in the garage from entering the living area and to](#)

I=Inspected

NI=Not Inspected

NP=Not Present

D=Deficient

I	NI	NP	D
---	----	----	---

ensure is always fire blocked.

⌋ Noticed door stops are missing or broken throughout the house which all must be added either on bottom wall trim, wall or on the door hinge. Should not have any doors hitting a wall or another door:kitchen,back hits the wall and opens outward;



Garage Doors

Type of Door(s):

⌋ Metal ⌋ Wood ○ Fiberglass

- ⌋ Some fastening hardware loose;
- ⌋ Door locking hardware is loose and/or missing
- ⌋ Doors and/or panels are bent or damaged
- ⌋ Tension springs are not safely secured

⌋ ⌋ ⌋

H. Windows - Comments:

⌋ Some windows are difficult to open or close at: ;White lithium grease should be applied to all window springs for ease of opening and longer life protection.

⌋ Some glass panes:should clean all paint and scuffs from all glass,



⌋ Some window lift supports are loose, damaged,:left in front bedroom not staying open all the way;adjust.



⌋ Some missing or damaged trim or latches or out of alignment at:damaged exterior trim in living room and not aligned at the top,

I=Inspected

NI=Not Inspected

NP=Not Present

D=Deficient

I	NI	NP	D
---	----	----	---



- .. Some missing and/or damaged screens at:
- .. Some missing and/or damaged blinds at:
- .. **Some windows have been drilled through for alarm sensors which will void the manufacturer's warranty unless the builder received approval and has the approval on file.** These drill holes must have a good caulk seal so that water will not penetrate into the wood and some need sealing;a loose sensor noticed.
- o Some absence of safety glass logo which should be present in all swinging doors, fixed or sliding doors,storm,unframed swinging doors,all door enclosures for tubs/showers and/or less than 60 inches on all windows above any standing, walking,water surface area and 3 feet horizontal from stairwells:
- .. Windows in sleeping areas are of inadequate size or over 44" from ground for egress at:

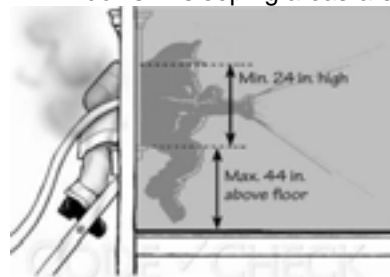

Bedroom Window Egress

The second exit required in a bedroom is usually a window. The dimensions of the openings are to ensure the residents an escape route, but equally important, they are designed to allow a firefighter with a backpack to enter. The opening must be at least 24" high and at least 20" wide, with a net area at least 5.7sq ft., per Table 15 in Code Check Building.

- .. Thermal pain window seals have failed and moisture has penetrated at:
- .. Inspection of the windows was limited due to furniture, window covers and/or stored items
- .. Burglar bars, clamps or blocked windows installed are a safety hazard. They do not provide adequate egress (escape) in the event of fire;
- .. Storm windows installed are a safety hazard, if they do not provide adequate egress in the event of a fire
- .. Windows are single paned at:

Note: The windows are double paned and most latches were operational at the time of the inspection.

I=Inspected NI=Not Inspected NP=Not Present D=Deficient

I	NI	NP	D
---	----	----	---

Note: All trim work, window sills, bathrooms, commodes, cabinets and other penetrations around the interior should be examined and improved as needed to provide a solid seal (caulk) against water penetration.

.. .. | ..

I. Stairways (Interior and Exterior) - Comments:

Interior/Exterior Steps, Railings, Stairways and Balconies

- .. Hand railing or vertical railing (or decorative trim) is loose/missing at one or more locations;
- .. Hand railing required if 4 or more risers;
- .. Vertical railing spacing or opening is greater than 4";(312.2 IRC.)
- .. Hand railing is not terminated properly;
- .. Improper dimensions of stair raisers and over 7 3/4";
- .. Hand railing or guardrail not at proper height between 34" to 38" or guardrail less than 36";
- .. Improper dimensions of stair treads and under 10";
- .. Improper dimensions of stair treads or risers of more than 3/8 inch adjustment between;
- .. Head clearance less than 6 foot 8 inches at any part of stairway;
- .. Light fixture and switch not present at top and bottom of stairwell landing if >6 risers (303.6.and 1 IRC);
- .. Enclosed accessible space below stairs req. 1/2 gypsum board and req. to be fireblocked under top and bottom of stringers,(602.8 and 311.3 IRC)

Note: Seems no two stairs are built alike and by code the risers should be a max of 73/4" and the tread should be a minimum of 10" with no more than a 3/8 adjustment between the tallest and shortest riser or largest and shortest tread run.

| |

J. Fireplace/Chimney - Comments:

Type of Fireplace:

.. Brick/Stone | Factory or Gas .. Free Standing

- .. Mantle is loose
- .. Firebox hearth inadequate size of less than 16" deep and 8 in to sides if opening <6sq ft or 20 in deep and 12 in to sides if opening>6sq ft;

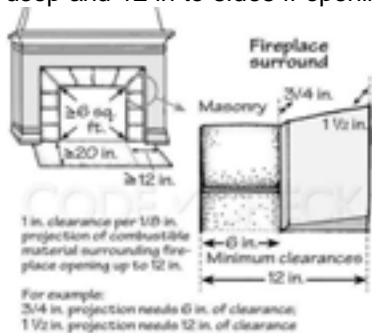

- Masonry Fireplace Clearances**
- .. Firebox hearth extension is less than 2 inches thick and/or hearth less than 4 inches;
 - .. Some brick mortar is loose and/or missing
 - .. Creosote build-up in firebox or flue;
 - .. Damper is in need of repair
 - .. No rain cap and/or spark screen in place is missing or damaged;
 - .. Hairline cracks in the firebox
 - .. Clean-out cover is loose and/or damaged
 - .. No firebox screen
 - .. No gas valve access panel
 - .. Starter wand is damaged or some closed holes;
 - .. Improper installation of gas log system
- | Damper is missing a clamp or bolt or is not blocked open and should be present in case of a gas

I=Inspected

NI=Not Inspected

NP=Not Present

D=Deficient

I NI NP D

leak, the damper must not be completely closed when a gas starter valve is present (even when direct draft holes are present;2432.1 IRC).



- .. Stator wand is missing the air-mixer valve;
- .. Currently the chimney flue is inaccessible. Building insulation in contact with a metal chimney can cause hot spots that can burn out over time. Contact the chimney manufacturer for exact requirements. In the absence of the manufacturer's requirements, a free space of at least 2" is recommended to all construction materials and insulation should be remedied for safety against the possibility of damage that can lead to a fire if determined the chimney is in contact.

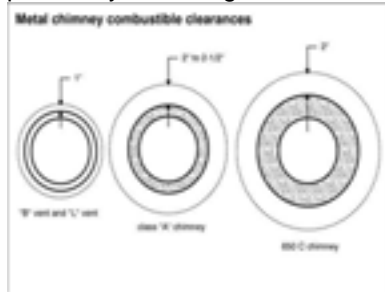

- .. No gas key located

Note: Chimneys should be cleaned by a professional chimney sweep on a regular basis if used often.

Note: This firebox is a gas burning unit which requires a damper clamp so that it cannot close completely and an air/gas mixer valve. The gas starter wand was lit and appeared to function properly except issues mentioned above.



h

K. Porches, Balconies, Decks, and Carports - Comments:

- .. Vertical railing spacing is greater than 4"
- .. Railing height is less than 36"
- .. Some decking fasteners are backing out
- .. Railing is loose or missing at one or more areas
- .. Some decking boards are loose or damaged
- .. Inadequate structural support members;
- .. Deck/porch/carport is not properly attached to main structure

IF an outdoor porch or deck is less than 30 inches from the ground the above does not apply, however may implement for safety.

I=Inspected NI=Not Inspected NP=Not Present D=Deficient

I	NI	NP	D
---	----	----	---

⌋ " " ⌋

L. Other - Comments:

⌋ Fence;loose picket side of master to name one.



- .. Gaps underneath the fence that should be addressed:
- .. Observed a dead tree which should be removed or monitored to ensure does not fall on house:
- .. Address not visible from the street or road,(321.1 IRC)
- .. Observed gate locks do not latch properly and should be adjusted:
- .. Some debris or bricks are leaning against the house/garage:
- .. Some bricks are stacked in garage and would be a good idea to spread the load;
- ⌋ Some wasps nests, insects or ant beds were observed at:ant piles,



- .. Some mailbox or flag issues were observed:
- .. Some other safety or tripping hazards exits around house:

Yeary Inspection does not perform Wood Destroying Insect (WDI) Inspections, however can or has recommended a good service provider to complete this portion of the inspection which is always recommended on pre-owned homes and most lenders require.

II. ELECTRICAL SYSTEMS

⌋ " " ⌋

A. Service Entrance and Panels - Comments:

- .. Service drop is loose and/or pulling away;
- .. Service drop, mast riser (pipe through roof) has open knockouts,less than 18 inches from roof, or more than 1 wire per opening;
- .. Service line or drip loop is less than 10 feet above the ground,12 above a driveway;

Main Disconnect Panel

Type of Wire:

- ⌋ Copper circuit breakers
- ⌋ Aluminum leads;

- .. Panel(s) are not labeled properly;
- .. Panel(s),breakers and all equipment are not UL labeled;
- .. Panel has more than 6 main disconnects;
- .. Panel top switch must be less than 6 feet 7 inches from the ground in the up position;
- .. Working space shall be 3 feet out from panel, 30 inches wide to 6 feet 1/4 inches high and 6 feet 6 inches head room with no more than 6 inches of shrubs/debris from the wall.
- .. Panel(s) are loose at the wall,not flush mounted, missing screws or pointed screws.
- ⌋ Improper cable bundling;all wires are entering at the top through one hole which is not fire stopped vs.spread at the top which is considered fire stopped which is a new regulation;

I=Inspected

NI=Not Inspected

NP=Not Present

D=Deficient

I	NI	NP	D
---	----	----	---

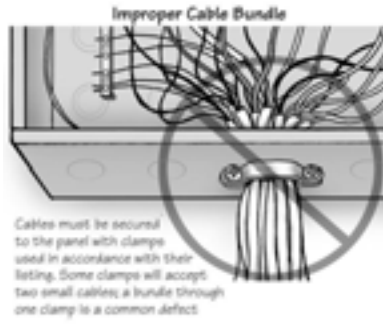

- .. Panel inner safety cover is loose or missing
- ⌋ Improper bonding locknut or connection; main strap not connected; [2008 NEC 250.92 \(A\) and \(B\)](#);

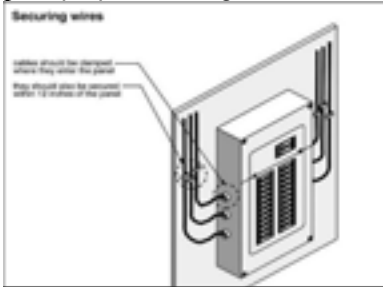

- .. Ground wire/rod could not be verified or buried in ground or behind bushes;
- .. Ground rod less than 6ft apart from each other or less than #6 rod size on 8ft rod;
- .. Double lugged wires of any kind under circuit breakers or two neutrals or more together under 1 screw on neutral bus bar;

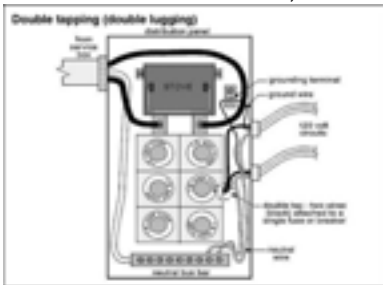

- .. Insulation damaged on conductors, wire bundled more than 2 inches;
- .. Ground wire not connected correctly (or broken) to grounding rod or a loose/improper (bronze or zinc) clamp in use and should be tightened;
- .. Concrete encased electrode in place with home that has a vapor barrier between the slab and the dirt.
- .. Incorrect size of breakers/fuses and/or loose breakers or improper trip wire used to connect;
- ⌋ Incorrect wire on breakers/fuses; *observed white wires used for hot current attached to a breaker which are not identified*, green for other than a ground and/or red and black for other than hot current; or main neutral wire not less than one size smaller than hot lead.



- ⌋ Lack of anti-oxidant grease on the aluminum service entrance conductors from the power company; all AL conductors.

I=Inspected

NI=Not Inspected

NP=Not Present

D=Deficient

I NI NP D



⌋ A/C living area condensing unit specifies a max amp breaker of 30 and a 40 amp breaker is in use;
⌋ A/C master condensing unit specifies a max amp breaker of 30 and a 40 amp breaker is in use;
Arc-Fault circuit breakers observed and properly installed for electrical receptacles in family rooms, dining rooms, living rooms, parlors, libraries, dens, bedrooms, sunrooms, recreation rooms, closets, hallways, or similar rooms or areas. This is a new regulation as of slab poured after September 2008 and homes built prior to this were not required to have arc fault protection except for bedrooms only and prior to mid 2,000's was not required at all and now current industry requires and cannot be sure this panel could hold the proper amount needed; Confirmed that 9 were in place and protected all of the above rooms except dining was gfci protected.

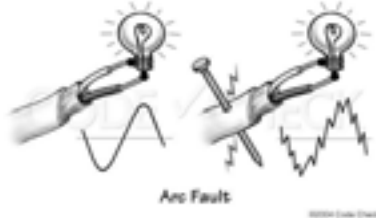

- ∴ Improper panel at separate structure and not a main disconnect or ground wire/ rod;
- ∴ This is a Federal Pacific Stab breaker panel that should be evaluated by a professional electrician and please refer to the Federal Pacific clause below that is recommended to add by Inspector Association;

Note: This panel is a 200 Main lug coming in from the City through an underground lateral. This panel is a SIEMENS brand rated for a 225 max AMP and is a aluminum conductor coming in from the power company and copper throughout the house located INSIDE GARAGE. The sub is a SQUARE D rated for a 125 max and in the garage.

Note: The panel is taken off and observed to ensure the conductors (wire gauge size) are proper for the size circuit breaker. If all circuit breakers are available the 15 AMP circuits are attached to 14AWG or larger, 20 to 12 AWG or larger, 30AMP to a 10AWG or larger and 40 AMP to 8AWG or larger, and 60 amp to a 6 awg or larger; which is within NEC regulation. The labeling is viewed, (not confirmed to be correct except for the AC), along with making sure there are not two wires under one circuit breaker. The grounding electrode should always be tight and rust free so that it holds a good ground.

I=Inspected

NI=Not Inspected

NP=Not Present

D=Deficient

I	NI	NP	D
----------	-----------	-----------	----------

Feet or Meters	Branch Circuits or Feeder Wire Size		Service Conductors Wire Size	
	Minimum	Maximum	Minimum	Maximum
15	14	21		
20	14	21		
25	14	21		
30	14	21		
35	14	21		
40	14	21		
45	14	21		
50	14	21		
55	14	21		
60	14	21		
65	14	21		
70	14	21		
75	14	21		
80	14	21		
85	14	21		
90	14	21		
95	14	21		
100	14	21		
105	14	21		
110	14	21		
115	14	21		
120	14	21		
125	14	21		
130	14	21		
135	14	21		
140	14	21		
145	14	21		
150	14	21		
155	14	21		
160	14	21		
165	14	21		
170	14	21		
175	14	21		
180	14	21		
185	14	21		
190	14	21		
195	14	21		
200	14	21		
205	14	21		
210	14	21		
215	14	21		
220	14	21		
225	14	21		
230	14	21		
235	14	21		
240	14	21		
245	14	21		
250	14	21		
255	14	21		
260	14	21		
265	14	21		
270	14	21		
275	14	21		
280	14	21		
285	14	21		
290	14	21		
295	14	21		
300	14	21		
305	14	21		
310	14	21		
315	14	21		
320	14	21		
325	14	21		
330	14	21		
335	14	21		
340	14	21		
345	14	21		
350	14	21		
355	14	21		
360	14	21		
365	14	21		
370	14	21		
375	14	21		
380	14	21		
385	14	21		
390	14	21		
395	14	21		
400	14	21		

Sub Panels/A/C Disconnect

Type of Wire: Ⓟ Copper Ⓜ Aluminum

- Ⓜ Panel(s) are not labeled properly
- Ⓜ Panel(s) installed at improper location or disconnect behind condenser unit
- Ⓜ Panel cover(s) are loose at the wall
- Ⓜ Inadequate service space for sub panel
- Ⓜ Double lugged wires in use under circuit breakers or neutrals;
- Ⓜ One or more knockouts missing
- Ⓜ Incorrect size of breakers/fuses
- Ⓜ Grounds and neutrals on same bus bar or connected (strap must be removed);

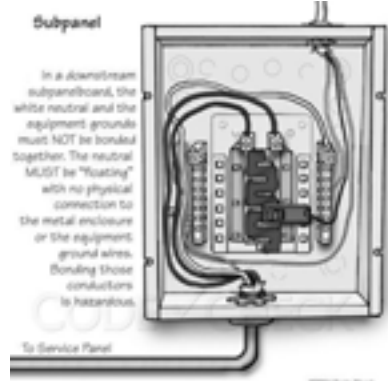

Ⓟ Observed that both A/C disconnect(s) over the A/C unit has the line load reversed. The line side (this panel is the OUTSIDE wires per the diagram) should always be the hot wire and load should be neutral and BOTH ARE reversed.



I=Inspected NI=Not Inspected NP=Not Present D=Deficient

I	NI	NP	D
---	----	----	---

⌋ " " ⌋ **B. Branch Circuits, Connected Devices, and Fixtures**

Type of Wiring: Copper

Comments:

- .. One or more junction boxes do not have covers or rain protective/weather resistant boxes for exterior locations in all damp or wet receptacle areas;[\(2008 NEC 406.8\)](#);
- .. One or more wiring connections or wire splices are not in junction boxes or fully enclosed conduit;
- ⌋ Wires loose on the wall;low voltage in back waiting for connection,rain sensor not connected.



- .. Branch circuits not correctly attached to panel;

Outlet and Switches

Type of Wire: ⌋ Copper .. Aluminum

- .. Observed one or more outlets, switches or electrical device installed through combustible material that are not flush mounted as required by code or is missing a plastic (fire rated enclosed spark ring) box at:may be under sink as seen above range and should be like Island;2nd picture.
- .. Observed one or more outlets, switches or electrical device installed through non-combustible material that are not a minimum of 1/4 inch mounted as required by code or is missing a plastic (fire rated enclosed spark ring) box at:
- .. Observed one or more holes inside the plastic or metal electrical boxes.
- .. Observed one or more outlets are not listed as tamper resistant receptacles [\(2008 NEC 406.11 which is current 08 regulation\)](#),and are for all 15A and 20A, 125V receptacles installed in all dwelling units with exception to over range and is recommended upgrading when children will be in the house.
- .. Observed a receptacle more than 12 inches under Island counter.
- .. Observed a receptacle on an Island counter with more than a 6 inch overhang.
- .. No receptacle on an Island counter that is 24+ inches long and 12 + inches wide,not present in a bathroom within 3 feet of each basin, more then 24 inches apart in kitchen, more than 6 feet apart in other rooms or over 6' 6" high on exterior.
- .. Observed a receptacle more than 12 inches under Island counter.
- ⌋ Observed and touched several loose outlets throughout the house that must be tightened- [\(by removing the front cover if present and tightening the inside screws and replacing the covers\)](#):some loose,broken,not flush to the wall or gaps around may have been marked;fan switch hanging in middle bedroom,



- .. Observed hot/neutral reverse,open grounds,bootstrapped wiring or other improper wiring at;
- .. Most or all the outlets are not grounded or are not the grounded type (typical of older homes with two wire systems);
- .. Aluminum wiring being used in outlets/switches not approved for aluminum wiring;(only purple wire nuts approved to connect copper and AL together);CO/LAR ok.
- .. Aluminum wiring connections are missing antioxidant compound if not rated for AL;
- .. Voltage tester indicated that some of the switch(s) are not properly grounded. Industry standard is

I=Inspected NI=Not Inspected NP=Not Present D=Deficient

I	NI	NP	D
---	----	----	---

to ground all non-grounded switches to reduce risk of electric shock.
Concealed connections of aluminum and copper wire was not inspected;

Inspection of outlets, switches and accessory connections is limited when occupied due to concealment, however all outlets are checked except ones plugged into phones, computers, TV 's or those behind heavy furniture.

Ground Fault Circuit Interrupt (GFCI) Safety Protection; (time line of regulation in blue)

- Kitchen: Yes No N/A 9 trip and reset to kitchen; required in 1987 within 6 ft of sink, 1996 was all that serve counter top outlets;
- Bathrooms: Yes No N/A all trip to master; required since 1975;
- Exterior: Yes No N/A all trip and reset to garage and front by gate is not aligned properly; required since 1973, 1978 was direct grade access and defined in 1987 as 6 feet 6 inches or less above grade, and all exterior in 1996.
- Garage: Yes No N/A 7 trip out of all 7; required in 1978 for all except not readily accessible(6 feet 8 inches or higher and a freezer etc.);2008 all including the overhead;
- Boathouse/Barn: Yes No N/A ; 1987 to present;
- A/C Unit: Yes No N/A ; same as exterior;
- Pool/Spa: Yes No N/A ; 1971 within 15 feet of water, 1984 within 20 feet of water in any direction; 1981 for motor and electrical equipment, 1987 indoor within 10 feet for pump or motor;
- Wet Bar / Laundry room: Yes No N/A ; 1993 within 6 feet of sink to serve as counter top outlets;
- Hydro/Whirlpool tub: Yes No N/A ; 1987 for motor and equipment, and 1999 receptacles within 5 feet.

- No GFCI protection at one or more locations in the above areas. This is considered a recognized safety hazard and in need of repair
- GFCI circuit not inspected at: _____

Electrical Fixtures

- Some light fixtures and/or bulbs did not function and could be either;
- Closet light fixture does not have proper clearance
- Some light fixture covers are damaged/missing; cover in kitchen and missing a globe (repaired while was there), hall door hits light,

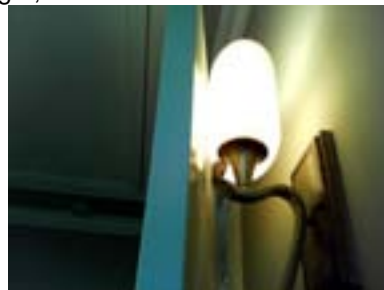
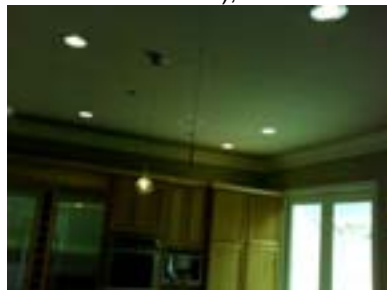

- Some light fixture globes are missing from the clothes closets which must be present per NEC standards;
- Some light fixture covers are missing over sinks and tubs which must be present per NEC standards;
- Ceiling Fans and/or light fixtures wobble or vibrate; slight in living room, slight in front bedroom on high,

Smoke and Fire Alarms; 2003 IRC (313.1 and 2)

- Alarm(s) are loose at the ceiling/walls
- No alarms installed - Safety Hazard
- Alarm(s) did not function - Safety Hazard;
- No alarms installed in each bedroom

I=Inspected NI=Not Inspected NP=Not Present D=Deficient
I NI NP D

- .. Alarm(s) are not hard-wired or connected; battery power along ok for remodel where no finishes removed,(313.2.1 IRC)
- o No alarms in hallways
- o Batteries are chirping;



Smoke Alarms:

Smoke detectors are always tested if a vacant residence or can confirm that the system is not being monitored at the time and if not sure may not test. All detectors should be interconnected such that the actuation of one alarm will actuate all the alarms in the individual unit and should provide an alarm that will be audible in all sleeping areas. Smoke detectors should be checked by the alarm monitoring company for proper operation.

Noticed 5 smoke detectors which all were checked and sounded, however not a true smoke detector check and not 100% sure that all upstairs and downstairs are interconnected, however sounded like at the time with only one person. Always recommend to replace batteries upon move in.

Other Electrical System Components

We DO NOT inspect security systems, Brinks Home Security will provide a free inspection for which we are paid a processing fee. Brinks Home Security will contact you at a later date at the phone numbers you have provided with a special offer and/or may have left a written inspection of sensors etc. on site.

Note: The clothes dryer outlet has a 4-prong connection and was checked to ensure it reached 240AMPS. Newer dryers use a 4-prong connection while older dryers use the 3-prong type which are out of code. (Gas outlet is provided for dryer);

- .. Because of the above checked issues on both Electrical sections could be evaluated by a professional electrician for a more in depth cost analysis of these or any other discovered; needed repairs.

III. HEATING, VENTILATION AND AIR CONDITIONING SYSTEMS

p

A. Heating Equipment

Type of System: Central

Energy Source: Gas

Comments:

- .. Floor or wall furnaces in use may be hazardous;
- .. Flue is loose, not angled properly or not properly connected to the unit;not vented to exterior,
- o Flue termination is an open cpvc pipe on roof vs. having a J cover to prevent water entry on high efficiency units;
- o Inadequate ventilation for combustable air
- o Access panel bent,not properly attached or wiring covers missing;
- o Flue is in contact and/or too close to combustibles
- o Rust at the burner and/or burner compartment
- o Improper clearance between door and unit

I=Inspected NI=Not Inspected NP=Not Present D=Deficient

I	NI	NP	D
----------	-----------	-----------	----------

- Combustible material under or touching the furnace
- Unit's blower fan and/or motor assembly vibrates;
- No separate shut-off switch located at filter door opening or post;
- No data plate present or verified;
- Flex gas line observed inside the unit
- No gas cutoff valve and/or improper gas valve
- Return air filter needs cleaning and/or replacement
- .. Gas is turned off and/or no pilot flame, however attempted to ignite when turned on
- Unit not properly grounded to outlet inside junction box (copper ground not connected properly);
- Gas leaks detected at: _____
- .. System(s) shows (show) signs of unit not working or very dirty. Recommend cleaning, servicing, and further evaluation by a licensed professional.

This/These unit(s) is/are a Split level LENNOX brand model # and serial # and determined was/were manufactured in 2010 by analyzing the data plate.



WHAT COULD BE DONE IF FUNCTIONING PROPERLY:

Note: The panel was removed and the heat was ignited. The heat displayed a nice blue flame and did not see any rust buildup. The heat was set on high as would go and ran for about 10 to 15 minutes and registered from **120 to 137F in living area except 1 closet to wall in center dining room is 110F and 139 to 142F in master area** using an infrared thermometer and testing each register. Over 110 F is a good read for this amount of time and this type of check helps to ensure the ductwork is connected to the register vent.



Note: Any temperature check with a laser or any instrument will vary during the check, however is still a consistent check.

⌋ .. ⌋

B. Cooling Equipment:

Type of System: Central - Air Conditioning

Comments:

Attic check with Duct thermometer - Supply Air Temp: 57.7 for front living unit and 59.5 on master unit - Return Air Temp: 76.8 for living area unit and 75.5 on master unit - Temp. Differential: 19.1 for living area unit and 16 on master unit - Degrees F; by checking the supply and return air in the duct or plenum with a duct thermometer in the attic. This is referred to as a Delta T.

I=Inspected

NI=Not Inspected

NP=Not Present

D=Deficient

I	NI	NP	D
---	----	----	---

- Temperature differential is not within range of 15-20 degrees Fahrenheit)

Note: Any temperature check with a laser or any instrument will vary during the check, however is still a good differential check.

- .. Freon lines not properly insulated at: ○ Condenser(s) ○ Air Handler(s) .. In Attic
- Condenser unit(s) coils dirty
- .. Condenser unit(s) are not level
- No data plate present or verified;
- No electrical cut-off within view of condenser unit
- Condenser coil(s) fins are damaged
- Air handler plenum is not properly sealed
- .. Condenser airflow is restricted by foliage;
- No drain pan and/or drain line under the air handler
- Rust, debris and or water was found in the overflow pan like it may have overflowed in the past and should be cleaned or replaced to ensure it does not leak;
- Debris and insulation was found in the overflow pan and should always be kept clean in case condensation occurs or primary drain line clogs. The secondary drain pan and line must be free of debris so will not clog which could result to water damage to the house.
- .. Condenser(s) installed too close to structure < 18";
- .. Termination of secondary condensate line is inadequate and will drip on wall.
- .. Condenser pad missing or inadequate height of 3";
- .. Cooling system could not be operated or properly inspected due to outside air temperature being less than 60 degrees Fahrenheit at time of inspection. [Operation at or below 60 degrees could cause damage to the unit and is not an accurate check since will not confirm proper cooling on a cool day in the Houston area.](#)
- .. System(s) shows (show) signs of not working properly, rust or water in emergency overflow pan and/or an out of range read. Recommend cleaning, servicing and/or further evaluation by a licensed professional;

Type- HONEYWELL-Thermostat located in THE LIVING ROOM that controls entire house. [\(If locked and a HONEYWELL, try system,hold 3 and 5 at same time,610 to adjust cool and 600 for heat to unlock\).](#)



Type:-LENNOX -EVAPORATOR COIL(S) IN ATTIC ARE - Model # and Serial # is below;2009;



I=Inspected NI=Not Inspected NP=Not Present D=Deficient

I	NI	NP	D
---	----	----	---

Type:LENNOX-LIVING AREA CONDENSER UNIT - Model # and Serial # is below with a min of 20 AMPS and max circuit breaker of 30 AMPS and is 3 ton unit manufactured in 19th week of 2010 by analyzing this data plate.



Type:LENNOX-MASTER CONDENSER UNIT - Model # and Serial # is below with a min of 20 AMPS and max circuit breaker of 30 AMPS and is 2.5 ton unit manufactured in 19th week 2010 by analyzing this data plate and closet to master.



One ton should cool 550 to 600 square feet of house and if a newer energy efficient house between 600 to 700 and this combined **5.5 ton** unit should cool between **3,300 to 3,850** square feet or more without any issues.

Observed the secondary drain line terminates over the **BACK** which if water is ever noticed dripping from that downspout would indicate the primary line is clogged and water will be in the attic pan and attention is needed. The primary drain line could not be inspected, due to being covered with insulation, catwalk, and or/ lack of accessibility and cannot always be certain that a pipe is not broken or connected properly, however only noticed 1 outlet in master sink; may be t'ed together, should investigate.



⌋ " " ⌋

C. Duct System, Chases, and Vents - Comment:

Type of Ducting: ⌋ Flex Ducting ○ Duct Board " Metal Ducting

⌋ Ducting is kinked or restricted in one or more places which may be affecting airflow or found a heat differential less than 8 degrees per room at: **The heat was set on high as would go and ran for about 10 to 15 minutes and registered from 120 to 137F in living area except 1 closet to wall in center dining room is 110F and 139 to 142F in master area** using an infrared thermometer and testing each register.

I=Inspected

NI=Not Inspected

NP=Not Present

D=Deficient

I	NI	NP	D
---	----	----	---



- Some ducting moisture barrier or plenum is damaged, missing and/or deteriorated or not sealed properly at the connections or unit;
- There is no central airflow to the room addition(s) and/or garage conversions;

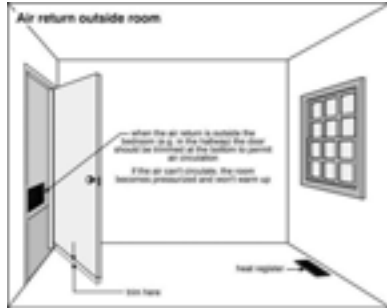

- Some supply registers have a heavy debris, rust or mildew buildup on the outside grates and/or very dirty return chase;
- Some registers are loose or not flush against the wall/ceiling; master return,



- Return air plenum is open inside and not sealed and/or wires, plumbing pipes which may be allowing air to escape and could be enclosed with duct board for increased efficiency and cover wires/pipes even when on an interior wall.
- Ducting is lying on the attic floor or resting against each other throughout the attic which should be well suspended throughout the attic;
- **Return air filters are present throughout the house and should be replaced because are dirty;**
- 12x12x1 ○ 12x24x1 ○ 16x25x1 • 20x25x1 • 20x30x1; ▫ 2 /16x25x4-in line/attic;

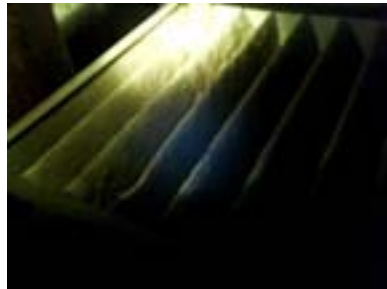

Each return air filter is checked for proper installation or for dirty filters and the chase is viewed inside to ensure the above issues do not exist.

• If a heavy buildup on grates, substance inside return or supply vents are observed would recommend to clean and/or replace the duct system.

I=Inspected

NI=Not Inspected

NP=Not Present

D=Deficient

I NI NP D

IV. PLUMBING SYSTEM

Ⓟ ⋯ ⋯ Ⓟ

A. Water Supply System and Fixtures

Location of water meter: Front yard

Location of main water supply valve: east side-outside

Static water pressure reading: 75 psi

Comments:

Water Source: Ⓟ Public ⓪ Private

Sewer Type: Ⓟ Public ⓪ Private

WHEN OPERABLE AND WATER IS ON:

Note: Checked all faucets for hot/cold labeling, drain leaks, slow draining, and leaks throughout each room. Checked each tub and shower for shower head leaks, drain pan leaks and insured all stoppers held water including sinks. The water slowly drip and was filled and drained at large amounts while inspecting that room.

Sinks

- ⓪ Leakage around sink(s) at:
- ⓪ Min. water service is under 3/4 in (2903.7 IRC),
- ⓪ Faucets have low water pressure
- Ⓟ Drain stop operable, but not properly holding water or draining, half bath,
- ⓪ Hot and Cold water reversed
- Ⓟ Loose/damaged faucet handles; laundry loose,



- ⓪ Finish on sink is damaged
- ⓪ No shut-off valves under sink
- ⓪ Drains have no visible P-trap
- ⓪ Water hammering noted
- ⓪ Caulking or grout in need of repair
- ⋯ Vegetable sprayer inoperable/leaking
- ⓪ Overflow not working
- ⓪ Porcelain/counter chip;
- ⓪ Sink not properly attached or secure to counter or missing clips under kitchen.

Bathtubs and Showers

- ⓪ Leakage around tub(s)
- ⓪ Faucets have low water pressure
- ⓪ Water hammering noted
- ⓪ Leakage around shower(s)
- ⓪ Absence of safety glass enclosure
- ⓪ Shower head is leaking;
- ⋯ Shower head is loose or missing;
- ⋯ Shower or tub has rust behind drains/faucets,
- ⋯ Hot and cold water reversed;
- ⓪ Loose/damaged faucet handles
- ⓪ Improper slope of shower floor
- ⋯ Tile loose and/or missing;

I=Inspected

NI=Not Inspected

NP=Not Present

D=Deficient

I	NI	NP	D
---	----	----	---

- Shower diverter valve not operating
- .. Shower diverter valve allowing water from tub faucet when shower is in operation;
- .. Enclosure needs to be sealed; or bottom drip guard damaged;
- .. Shower walls with installed shower heads shall be finished with a nonabsorbent surface (tile, fiberglass, etc.) not less than 6 feet above the floor, (R307.2);
- .. Caulking or grout in need of repair or (could be mildewed caulk in place);
- Drain stop inoperable or missing
- Soap dish missing
- Porcelain chip

⌋ Access panel is missing behind overflow and faucets; front. The tubs are not filled to the overflow (except on new construction or 1 year warranty) when cannot view the overflow drain underneath because would not want to damage a downstairs ceiling or interior wall, however should check and monitor the overflow drains to ensure the gaskets are tight and not deteriorated and do not leak. Yearly Inspection has viewed many homes that leak from the tub overflow on older homes and checks when an access panel is present.



- Access panel is loose on the wall, screws are not holding panel snug to wall or not secured properly;
- Leakage from overflow or past leakage and a lot of extra caulk;

Commodes

- Seal leaking between tank & bowl;
- .. Loose at floor mounting and may need reseating;
- Bowl or tank is cracked/damaged;
- Flush mechanism inoperable;
- Tank water level is too high;
- Tank lid broken or missing;
- Bowl refill tube is missing;
- Flapper valves are faulty;
- .. Commode seat is loose/damaged;
- Porcelain chip observed;

Washing Machine Connections

- .. Washing machine connected at this time - faucets, drains not tested for proper operation;
- .. Leakage or corrosion at plumbing connections;
- .. Dryer vented into attic or garage;
- .. Washing machine is missing a pan and/or drain line if on the 2nd or 3rd floor;

SHOULD PERFORM IF WATER IS ON;

Note: Checked the laundry tub with a small hose to ensure that hot was on the left and that cold was on the right and made sure that leaks were not prevalent at the time of inspection. The water was operated for about 15 minutes and seemed to drain fine.

I=Inspected

NI=Not Inspected

NP=Not Present

D=Deficient

I	NI	NP	D
---	----	----	---



Exterior/Attic Plumbing

Outside Water Pressure: 75 PSI in the front behind garage and 75 on side of garage, 75 PSI in the back, 75 PSI on the east side at shut off was observed when checked with a PSI Water gauge. The standard water pressure should be between 40 to 80 PSI and if over 80 PSI is considered out of range.



- Under 40% water pressure requires a booster pump and over 80% must be regulated, (2903.3 IRC);
- No backflow prevention at hose bibb(s):



- Faucet handles are loose, damaged, missing or just leak/drip at the nut or handle when the psi gauge is attached. This could be as simple as tightening, however not certain.
- Leakage or corrosion observed at:
- Insulation missing and/or needs reattaching;
- Sprinkler Anti-siphon is secure in ground or wall,



Main water pipes are Plastic CPVC-PVC and PVC is not recommended as a water supply line inside the house Copper Galvanized and cast iron;

I=Inspected NI=Not Inspected NP=Not Present D=Deficient

I	NI	NP	D
---	----	----	---

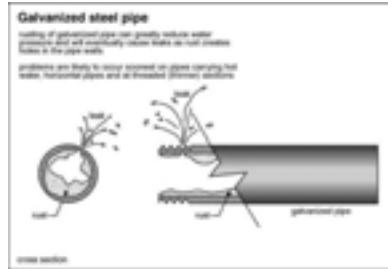

Main sewer clean out is located } Front garage corner and 2 in back yard;

Must remember that galvanized piping will corrode from the inside out and an older property could have potential past,present or future leaks. Cast Iron is recommended to perform a water static test if over 40 years old and may be nearing the end of its life cycle.

Because of the above and below checked issues on all Plumbing sections could be evaluated by a professional plumber for a more in depth cost analysis of these or any other discovered; needed repairs.

} }

B. Drains, Wastes, and Vents - Comments:

Portions of the plumbing system concealed by finishes and/or storage (below sinks, etc.), below the structure, and beneath the yard were not inspected. It would be wise to contact your insurance carrier to determine if damage caused by possible leaks beneath the house will be covered under your Home Owner's Policy. The only sure way to determine the true integrity of a vent and waste system is to perform a static test and inspection. If elected, a licensed plumbing contractor or leak detection expert would perform this service.

- } Drain not draining quickly or takes a while for sink or tub to drain and may be clogged or blocked at: master tub drains slow,
- } Drain may not be connected properly or some leakage; very strong smell in half bathroom;
- .. Air admittance valve must be 6 in above insulation in attic,open and accessible to air flow,(3114.4/5 IRC);
- .. Dvw a min of 1 1/2 in,(3108.3 IRC),

} }

C. Water Heating Equipment

Energy Source: Gas

Capacity: 50 Gallons

Comments:

Approx. age: 3 Year Manufactured was 6/28/2007

Hot water temp. is: 124 to 132 Degrees Fahrenheit tested at kitchen sink (Water temp above 110 degrees F could be a safety hazard);

TIME/TEMPERATURE RELATIONSHIPS IN SCALDS*

Temperature	Time to Produce
120°F	More than 5 min-
125°F	1- 1/2 to 2 Min-
130°F	About 30 Seconds
135°F	About 10 Seconds
140°F	Less than 5 Sec-
145°F	Less than 3 Sec-
150°F	About 1-1/2 Sec-
155°F	About 1 Second
160°F+	Instantaneously

*Table Courtesy of Shivers Burn Institute

- .. Corrosion and/or signs of an intermittent leak at isolation valve, and/or plumbing connections or underneath unit;
- .. Unit is located in a Garage or adjacent area and is not elevated so that its ignition source is 18" above the floor
- .. Unit was not in operation at the time of inspection. Hot water temperature was not checked, inspection limited
- .. Unit has no drain pan and/or drain line installed under the unit if on second floor, attic or next to an

I=Inspected

NI=Not Inspected

NP=Not Present

D=Deficient

I	NI	NP	D
---	----	----	---

- inside wall or unit blocking opening.
- Unit drain pan has debris in pan,
- Leakage around bottom of unit
- Leakage around connections
- Leakage around storm collar or flue
- Flue is loose, damaged or poorly connected;
- Hot and cold water lines reversed
- Unit is not properly vented for combustion air
- Cold water shut-off inoperable and/or missing
- Flue is in contact or too close to combustibles
- Did not view a disconnect in line of site on electric unit
- Unit is not enclosed or protected from damage;
- One or more covers are missing/damaged or drain faucet is missing;
- Improper gas line materials
- Mineral deposit noises can be heard in the unit
- This appliance is missing the drip leg or sediment trap on the gas lines as explained in the water section.
- This appliance is not bonded and or grounded at the water heater which is required if copper piping is used;



- No data plate present or verified;

Water Heater Temperature and Pressure Relief Valve

- T/P valve has no drain line and/or less than 3/4 inches
- Drain line is not plumbed to exterior
- T/P valve not installed at designated location
- Drain line runs uphill at some point
- Corrosion and/or leakage at connections including the TRP not properly resetting after operated;
- Drain line is threaded at termination point

Type:A.O.SMITH and the info in below picture. **The TRP valve is NOT tested** (except for new construction, warranty inspections, 3 year old homes or less that are vacant) or operated at the time of inspection due to sometimes if has not been tested in the past year or so may not close properly leaving a constant water drip from the TRP line, however should always keep the pan clean and wiped down and test the TRP valve each year as to keep the rust and sediment buildup to a minimum. On homes 3 years or older may consider replacement of TRP valve if appears corroded;

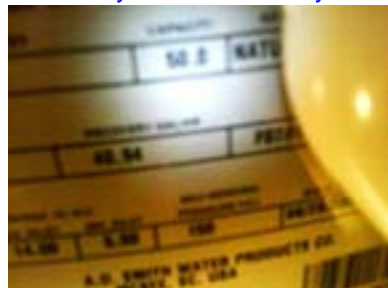

I=Inspected NI=Not Inspected NP=Not Present D=Deficient

I	NI	NP	D
---	----	----	---

Ⓟ " " "

D. Hydro-Massage Therapy Equipment - Comments:

- Ⓟ Access panel is inaccessible;
- Ⓟ Leakage around and/or under unit
- Ⓟ Unit does not operate
- Ⓟ Lack of ground fault circuit interrupter;
- Ⓟ The motor for the hydrotherapy tub was not accessible, thus not visible for inspection. Proper grounding/bonding could not be verified. Ideally a readily operable inspection door should be provided in order to access the whirlpool motor.
- Ⓟ Deficiencies in ports, valves, grates and covers
- Ⓟ Electric motor not bonded
- Ⓟ Vacuum switch does not operate
- Ⓟ Improper location of unit switch

Operated the jets for several minutes and checked for GFCI,leaks and all other accessible items and confirmed that 6 jets are working including the suction and has access;



V. APPLIANCES

Ⓟ " " "

A. Dishwasher - Comments:

- Ⓟ Unit leaking at bottom or from the drain vent because clogged or not connected properly;
- Ⓟ Unit hardwired (should be plug device)
- Ⓟ Anti-siphon loop at the drain line is missing and/or the loop is not tacked high enough to keep the waste water from backing into the dishwasher;
- Ⓟ Soap dispenser not functioning properly, missing rack rollers or sprayer parts missing.
- Ⓟ Unit is slightly loose in cabinet and most likely needs screws or tightened bottom;
- Ⓟ Rust present in interior of unit or racks,
- Ⓟ Door seal damaged or door is off hinge and/or damaged;
- Ⓟ Heater does not work for drying
- Ⓟ Water not draining;

Note: Operated the dishwasher and appears to function properly. This unit is a THERMADOR brand and model/serial # is below.



Ⓟ " " "

B. Food Waste Disposer - Comments:

- Ⓟ Unit leaking
- Ⓟ Unit hardwired (should be plug device)
- Ⓟ Electrical cord is not properly secured, not fully enclosed in conduit or missing the clamp;
- Ⓟ Corrosion present on or inside unit;

I=Inspected NI=Not Inspected NP=Not Present D=Deficient

I	NI	NP	D
---	----	----	---

- .. Splash guard damaged
 - .. Unit drain below P-Trap
 - .. Unit is very loud or vibrating during use
- Operated during inspection and appeared to function properly at the time.

⌋ ⌋

C. Range Exhaust Vent - Comments:

- .. Filter is dirty/greasy;
 - .. Light not functioning;
 - .. Vent pipe terminates improperly or does not completely vent all air to the exterior. The range is not the best system because it circulates the air back into the kitchen vs. to the exterior, however appeared to function at the time of inspection. Prefer the type system that takes the air to the exterior vs. recycling inside the house;
- ⌋ Fan assembly flue may not be aligned properly and level off just a little,



- .. Control knobs/switches defective or missing;
- .. Fan and/or blower does not operate properly or air is leaking/escaping around the flue that needs attention;

⌋ ⌋

D. Ranges, Cooktops, and Ovens - Comments:

Range Type: Checked below when present or operable;

⌋ Gas; and has a 240 ready outlet-The unit is gas and was tested for consistency of flame and viewed in low, med and high functions to ensure it held a consistent flame during the time viewed. The unit registered around 266 to 432 F when checked with a laser thermometer on low and appeared consistent which was only on for a minute or so for each setting.

- .. Control knobs are loose,damaged and/or missing
- .. Gas leaks were detected around unit
- .. Burners do not operate at high and low settings;
- .. Absence of gas shut-off valve or improper location;(behind appliance).
- .. Inadequate clearance from combustibles
- .. Improper materials used for gas connections
- .. Absence of anti-tilt device or should be tightened and secure;
- .. Deficiencies in the operation of the gas flame

Oven(s) ⌋ Electric .. Gas

Unit was tested at 350 degrees +15 last check which is good Degrees Variance (max 25 degrees);

- .. Gas is off so could not confirm;
- .. Control knobs are loose and/or missing
- .. Gas leaks were detected around unit
- .. Unit not securely mounted or loose in cabinet/counter.
- .. Broiler/heating element does not operate
- .. Deficiencies in door seal / tightness of closure

I=Inspected NI=Not Inspected NP=Not Present D=Deficient

I	NI	NP	D
---	----	----	---

- .. Thermostat sensing element not properly supported
- .. Inadequate clearance from combustibles
- .. Deficiencies in the operation of the gas flame
- .. Deficiencies in operation of timer,
- .. Interior light does not function;

The oven is a Thermador unit and was tested by placing on 350 F and checked two or more times with a Laser thermometer. Registered 319 F after the 10 minute timer was set and sounded and 7 minutes more was 404 F and was 365 F after the next 10 minutes. Warming drawer was 167 F at bottom.



The Broil (usually between 500 to 550 F) HI function was tested and registered 598 F in the center with laser thermometer after several minutes which is high read.

Note: Any temperature check with a laser or any instrument will vary during the check, however is still a consistent check.

⌐

E. Microwave Oven - Comments:

- .. Deficiencies in door seal / tightness of closure
- .. Does not operate by heating a container of water
- .. Interior light does not function
- .. Timer does not function
- .. Loose in cabinet

Operated on manual and 1 and 2 minute express mode and heated water.

.. .. ⌐ ..

F. Trash Compactor - Comments:

- .. Key is missing and/or door does not lock
- .. Unit not securely mounted
- .. Ram does not operate
- .. Excessive noise and vibration

⌐

G. Mechanical Exhaust Vents and Bathroom Heaters - Comments:

- .. Units are loose at ceiling and/or wall;
- .. Fan not present in bathroom or laundry room that does not have a window opening;
- .. Heat lamp timer does not work
- .. Unit motors and/or fans are noisy
- .. Missing covers on unit(s)
- .. Unvented gas wall heaters are considered a fire and safety hazard and are no longer recommended
- .. One or more vented to the attic (1501.1 06 IRC)or could not confirm;
- .. One or more grates need vacuuming;

⌐ ⌐

H. Garage Door Operator(s) - Comments:

- .. Auto safety reverse does not work - Safety Hazard;failed the block test;
- .. Switch is installed within reach of children
- .. Springs and or parts;may need greasing/oiling or could be loose because was loud during operation.

I=Inspected

NI=Not Inspected

NP=Not Present

D=Deficient

I	NI	NP	D
---	----	----	---

- .. Missing safety wire inside door springs
- .. Switch is loose or too damaged to operate opener
- ⌋ Electronic sensors not installed at proper heights;3 about 7 inches; **all should range between 4 to 6 inches from the ground.**
- .. Unit(s) are loose or not properly secured to ceiling
- .. Electronic sensors do not operate
- .. No safety quick release rope to disable opener
- .. Latch device is not secured or blocked properly so that it cannot be latched which is a must with automatic door openers in use;
- .. Remote door opener not observed or present;
- ⌋ Missing the support shield on the top of the door which is required unless the manufacture states otherwise;



Note: **Automatic Use:** The garage door should be checked for anti-reverse using a block to reverse the door when it is touched and should be tested for motion sensors by waving a foot in front and should be within 6 inches to the floor. Should have a support shield on the back of the door, and the springs and rails should be working properly. The latch should be secured properly which is a must with automatic doors.

All these above requirements should be met if installed;

⌋ .. ⌋

I. Doorbell and Chimes - Comments:

- .. Doorbell did not function;
- ⌋ Doorbell switch/cover is loose or damaged;loose on inside hall wall and could not hear front doorbell so may investigate with 2 people.



- .. Doorbell light appeared to be dim, painted over or out;

⌋ .. ⌋

J. Dryer Vents - Comments:

- ⌋ Dryer vent door cover is missing;

I=Inspected

NI=Not Inspected

NP=Not Present

D=Deficient

I NI NP D



- .. Dryer vent is not vented to the exterior wall or roof;or did not view/confirm,
- .. The dryer hose is too long and seems to be bunched/kinked or clogged. May want to shorten.
- .. The dryer hose is over 25 feet to termination
- .. The dryer vent is missing the blower, access to the plug outlet or disconnect;

VI. OPTIONAL SYSTEMS

⌋ .. ⌋

A. Lawn and Garden Sprinkler Systems - *Comments:*

Note: Tested all zones for proper spraying and functioning heads. The items in the summary are areas of concern. This is a HUNTER SRC PLUS system with 6 posted zones. Discovered a total of about 70 heads at the time of inspection. The anti-siphon is 30.5 inches tall.



- o The anti-siphon was not discovered and or appeared to be less than 6 inches above the tallest head at _ inches, which is the code;

STATION 1:

Observed about 12 total heads at; front yard both sides of driveway;



STATION 2:

Observed about 17 total heads at;front beds;



I=Inspected

NI=Not Inspected

NP=Not Present

D=Deficient

I	NI	NP	D
---	----	----	---

STATION 3:

Observed about 14 total heads at; 8 in front east side and 6 in back and 1 under rocks is covered or broken,



STATION 4:

Observed about 7 total heads at;back east side;2 spray the fence wall,



STATION 5:

Observed about 13 total heads at;all along back wall and several spray the wall which should be adjusted;



STATION 6:

Observed about 7 total heads at; back west yard and about 2 spray the wall which should be adjusted;



p . . .

B. Gas Supply Systems - Comments:

- .. May paint and protect gas line at meter where enters the wall;
- .. Missing gas drip leg or sediment P-trap downstream of the equipment shut off valve as close to the inlet of the equipment on gas line, *(G2419.2 and 4)*;
- .. Gas shut-off valve inoperable,not within 6 ft of appliance & ahead of union and connector and/or wrong type for appliances;
- .. Gas leaks detected around unit;may be at connection on gas line or at pilot housing if on outside of

I=Inspected

NI=Not Inspected

NP=Not Present

D=Deficient

I	NI	NP	D
---	----	----	---

furnace or water heater;

• Gas lines pass through bldg or appliance wall and/or is longer than the max length of 3 ft and 6ft for range and dryer, [\(2422.1.2.3 IRC\)](#);

• Absence of gas shut-off valve or improper location;(may be behind appliance).

• Gas lines and water lines are both galvanized (same color) and gas lines should be marked/identified.

p • • •

C. Other Built-in Appliances - Comments:

Note: Did check the (Thermador) refrigerator with laser one time and got a 41 F and the freezer registered 16 F and the wine (Kitchenaid) rack was 41F , however is not a complete check that would be needed to inform that it is working properly. Just a courteous temperature check.



Did not check the built in (THERMADOR) café center.



Foundations

Cracks in exposed concrete floors; few small chips in garage

Cracks in sidewalks, driveway, patio or garage which is very common; may seal at front patio along wall, end of driveway to name some

Wood form strips or other wood observed next to the slab which are conducive to wood destroying insects, which could be removed and replaced along with all cracks sealed with blown in foam covered with a thick layer of caulking; front patio area against wall

Nails or metal is exposed which could be a hazard and could be removed and covered; noticed side of garage

Grading & Drainage

Improper drainage from foundation and not a decline at all locations away from slab and/or a 6 inch decline at 10 feet away or less than a 5% slope to swale when barrier prevents 6in/10ft; front mulch needs adjusting

Erosion or ponding next to foundation/driveway or in yard; may adjust or monitor back corner, under valley runoff

Downspout is missing the splash blocks at several locations causing water to sit against the house

Roof Covering Materials

Some damaged or raised shingles throughout; 1 tear, a few raised on front over garage and ridge, several discolored/scuffed under front dormer and back noticed

Observed some exposed nails and/or staples showing that should be covered or caulked as part of routine maintenance; a few nailed low

Debris, nails, straw, and/or leaves on the roof that must be kept clean so that it does not damage the roof

Storm collars are not caulked completely on furnace/water heater flues and/or could view daylight from attic access; furnace

Flashing in need of repair; may paint valley flashing

Roof Structure & Attic

Dormers; unpainted windows; preference if homeowner wants painted

Roof support; observed 1 or more rafters that are not fully flush against the ridge board (some poor cuts) or do not meet or align on both sides (off tension) which could be blocked; another rafter next too sistered past the purlins or other methods or just monitored; some specifics are a poor cut over living area furnace, garage and marked a few, however no immediate cause for concern

; a few rafters on kitchen side in center are nailed off center down past ridge board and a brace is loose in front of hall access and marked

Open chase should be fire blocked every 10 feet horizontally or vertically including around duct penetrations, between floors, and other openings and currently if a fire occurred could serve as a chimney; side front wall

Current regulation requires all wires within 6 feet of the attic opening to be protected and observed unprotected electrical wires near the opening. This could lead to wire damage and possible electrical shock or potential fire hazard.; master access

The recessed lights should be insulated ceiling lights since insulation or combustible material is touching the canister or closer than 3 inches. Even when these lights are air-tight or IC lights it is a good idea to pull all insulation away from the canisters because they can shut off due to getting too hot; over master tub going off and on

Lack of weather-stripping on the outside edge of hall access

Lack of fasteners through all brackets or brackets missing on edge for proper support; missing on 2, several in master and garage access

Walls (Interior and Exterior)

Gaps or cracks underneath sinks around pipes, outlets, etc.; may seal under kitchen sink

Cabinets, counter, mirror or drawer issues: some chips marked, nail through peninsula, no hardware or bumpers inside, clean counter and scratches, seam in kitchen counter, cabinet doors by dishwasher not aligned properly

Observed several paint discolorations and scuff marks throughout the house; some marked in kitchen, pantry, bathroom, around master tub

Observed several paint chips or sheet rock cracks throughout; several in garage

Fascia/trim boards are damaged at several areas; some damage in front patio, may address in front, seal or add trim at bottom of garage

Mortar is separated or missing in some areas; between some bricks at corners, around windows, front or back porches, front fence

Caulking/sealant is separated or missing in some areas and should block/seal any and all openings between the wall and trim work, b/t brick and stucco

Siding shingles are cracked, loose or missing; plaster scrape on back patio, buckled on top of chimney, back of outside chimney to name some

nail on side of front bedroom

Ceilings & Floors

Ceiling cracks or imperfections in some areas (very common in vaulted ceilings) at; master bathroom

Paint discolorations; kitchen, scratch in formal, master bath shower, center of master, paint around kitchen fixtures to name some

Floor cracks, scratches, or grout/seal openings in some areas; grout opening in center of living room, back kitchen door and a few scratches

Carpet and floor covering is stained; stain in middle room

Observed tiles that sounded hollow when tapped with a hard object which is a result of lack of adhesive spread evenly underneath tile, loose tile, air pockets or water has penetrated underneath the tile. Discovered 0 or more in the front entry, 0 or more in the kitchen, 0 or more in laundry, 0 or more in bathroom and 1 or more in master hall wing

Doors (Interior & Exterior)

Damaged doors at: paint discolorations, laundry, bedroom doors, most other sliding doors

Doors do not latch properly and/or striker plates need adjusting at: middle bedroom closet

Doors sealed poorly or add foam weather stripping; tear on garage door

[Most new construction keys are re programmed to change locks for buyers.](#)

Noticed door stops are missing or broken throughout the house which all must be added either on bottom wall trim, wall or on the door hinge. Should not have any doors hitting a wall or another door: kitchen, back hits the wall and opens outward

Windows

Some glass panes: should clean all paint and scuffs from all glass

Some window lift supports are loose, damaged; left in front bedroom not staying open all the way; adjust

Some missing or damaged trim or latches or out of alignment at: damaged exterior trim in living room and not aligned at the top

These drill holes must have a good caulk seal so that water will not penetrate into the wood and some need sealing; a loose sensor noticed

Fireplace/Chimney

Damper is missing a clamp or bolt or is not blocked open and should be present in case of a gas leak, the damper must not be completely closed when a gas starter valve is present (even when direct draft holes are present;2432.1 IRC)

Other Structural Systems

Fence;loose picket side of master to name one

Some wasps nests, insects or ant beds were observed at:ant piles

Yeary Inspection does not perform Wood Destroying Insect (WDI) Inspections, however can or has recommended a good service provider to complete this portion of the inspection which is always recommended on pre-owned homes and most lenders require

Service Entrance and Panels

Improper cable bundling;all wires are entering at the top through one hole which is not fire stopped vs.spread at the top which is considered fire stopped which is a new regulation

Improper bonding locknut or connection;main strap not connected;2008 NEC 250.92 (A) and (B)

Incorrect wire on breakers/fuses;observed white wires used for hot current attached to a breaker which are not identified,

Lack of anti-oxidant grease on the aluminum service entrance conductors from the power company;all AL conductors

A/C living area condensing unit specifies a max amp breaker of 30 and a 40 amp breaker is in use

A/C master condensing unit specifies a max amp breaker of 30 and a 40 amp breaker is in use

Observed that both A/C disconnect(s) over the A/C unit has the line load reversed. The line side (this panel is the OUTSIDE wires per the diagram) should always be the hot wire and load should be neutral and BOTH ARE reversed

Branch Circuits, Connected Devices, and Fixtures

Wires loose on the wall;low voltage in back waiting for connection,rain sensor not connected

Observed and touched several loose outlets throughout the house that must be tightened- (by removing the front cover if present and tightening the inside screws and replacing the covers):some loose,broken,not flush to the wall or gaps around may have been marked;fan switch hanging in middle bedroom

Exterior: Yes No N/A all trip and reset to garage and front by gate is not aligned properly;

Some light fixture covers are damaged/missing;cover in kitchen and missing a globe (repaired while was there),hall door hits light

Ceiling Fans and/or light fixtures wobble or vibrate;slight in living room,slight in front bedroom on high

Cooling Equipment

The primary drain line could not be inspected, due to being covered with insulation,catwalk, and or/ lack of accessibility and cannot always be certain that a pipe is not broken or connected properly,however only noticed 1 outlet in master sink;may be t'ed together,should investigate.

Duct System, Chases, and Vents

Ducting is kinked or restricted in one or more places which may be affecting airflow or found a heat differential less than 8 degrees per room at: The heat was set on high as would go and ran for about 10 to 15 minutes and registered from 120 to 137F in living area except 1 closet to wall in center dinning room is 110F and 139 to 142F in master area using an infrared thermometer and testing each register

Some registers are loose or not flush against the wall/ceiling;master return

Return air filters are present throughout the house and should be replaced because are dirty

2 /16x25x4-in line/attic

Water Supply System and Fixtures

Drain stop operable,but not properly holding water or draining,half bath

Loose/damaged faucet handles;laundry loose

Access panel is missing behind overflow and faucets;front

Drains, Wastes, and Vents

Drain not draining quickly or takes a while for sink or tub to drain and may be clogged or blocked at: master tub drains slow
Drain may not be connected properly or some leakage; very strong smell in half bathroom

Water Heating Equipment

Hot water temp. is: 124 to 132 Degrees Fahrenheit tested at kitchen sink (Water temp above 110 degrees F could be a safety hazard);

Dishwasher

Unit is slightly loose in cabinet and most likely needs screws or tightened bottom

Range Exhaust Vent

Fan assembly flue may not be aligned properly and level off just a little

Ranges, Cooktops, and Ovens

Registered 319 F after the 10 minute timer was set and sounded and 7 minutes more was 404 F and was 365 F after the next 10 minutes. Warming drawer was 167 F at bottom

The Broil (usually between 500 to 550 F) HI function was tested and registered 598 F in the center with laser thermometer after several minutes which is high read

Garage Door Operator(s)

Electronic sensors not installed at proper heights;3 about 7 inches; all should range between 4 to 6 inches from the ground

Missing the support shield on the top of the door which is required unless the manufacture states otherwise

Doorbell and Chimes

Doorbell switch/cover is loose or damaged;loose on inside hall wall and could not hear front doorbell so may investigate with 2 people

Dryer Vents

Dryer vent door cover is missing

Lawn and Garden Sprinkler Systems

STATION 3:

Observed about 14 total heads at; 8 in front east side and 6 in back and 1 under rocks is covered or broken

STATION 5:

Observed about 13 total heads at;all along back wall and several spray the wall which should be adjusted

STATION 6:

Observed about 7 total heads at; back west yard and about 2 spray the wall which should be adjusted